

# AMS E-GEAR

MODELS 3000 / 4000 / 5000 / 6000 / 7000 / 9000

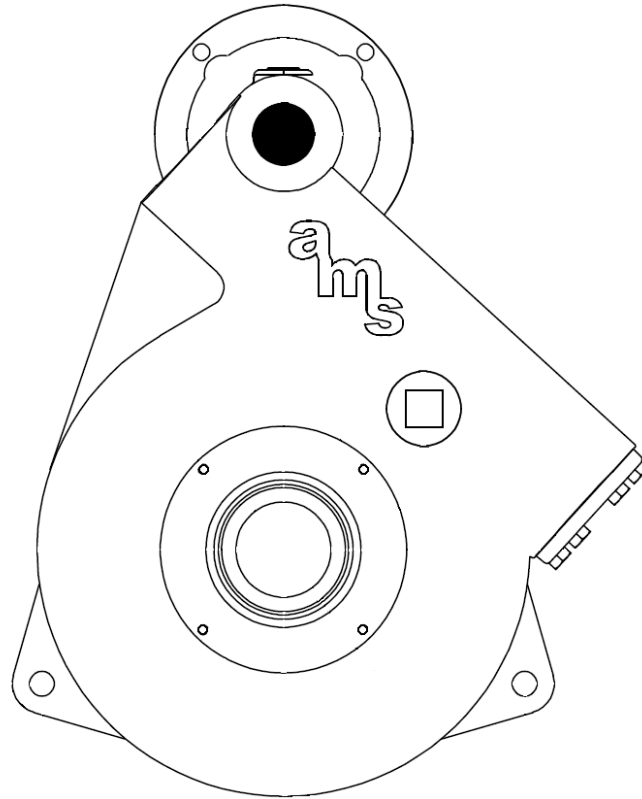

## **! IMPORTANT! READ BEFORE INSTALLATION**

- **DO NOT OVERTIGHTEN DRIVE BOLT/NUT**  
Overtightening can place pressure on the hub of the gear casting and cause it to crack
- **DO NOT REPLACE DRIVE BOLT WITH STAINLESS STEEL**  
The provided bolt is casehardened to withstand extreme torque.
- **GEAR SHOULD BE MOUNTED WITH MOTOR AT TOP ONLY**  
Mounting positions other than this can cause internal components to lose lubrication which can lead to failure.
- **LUBRICATE MOTOR SHAFT BEFORE INSTALLATION**  
Installing without anti-seize can cause issues later if motor needs to be replaced.

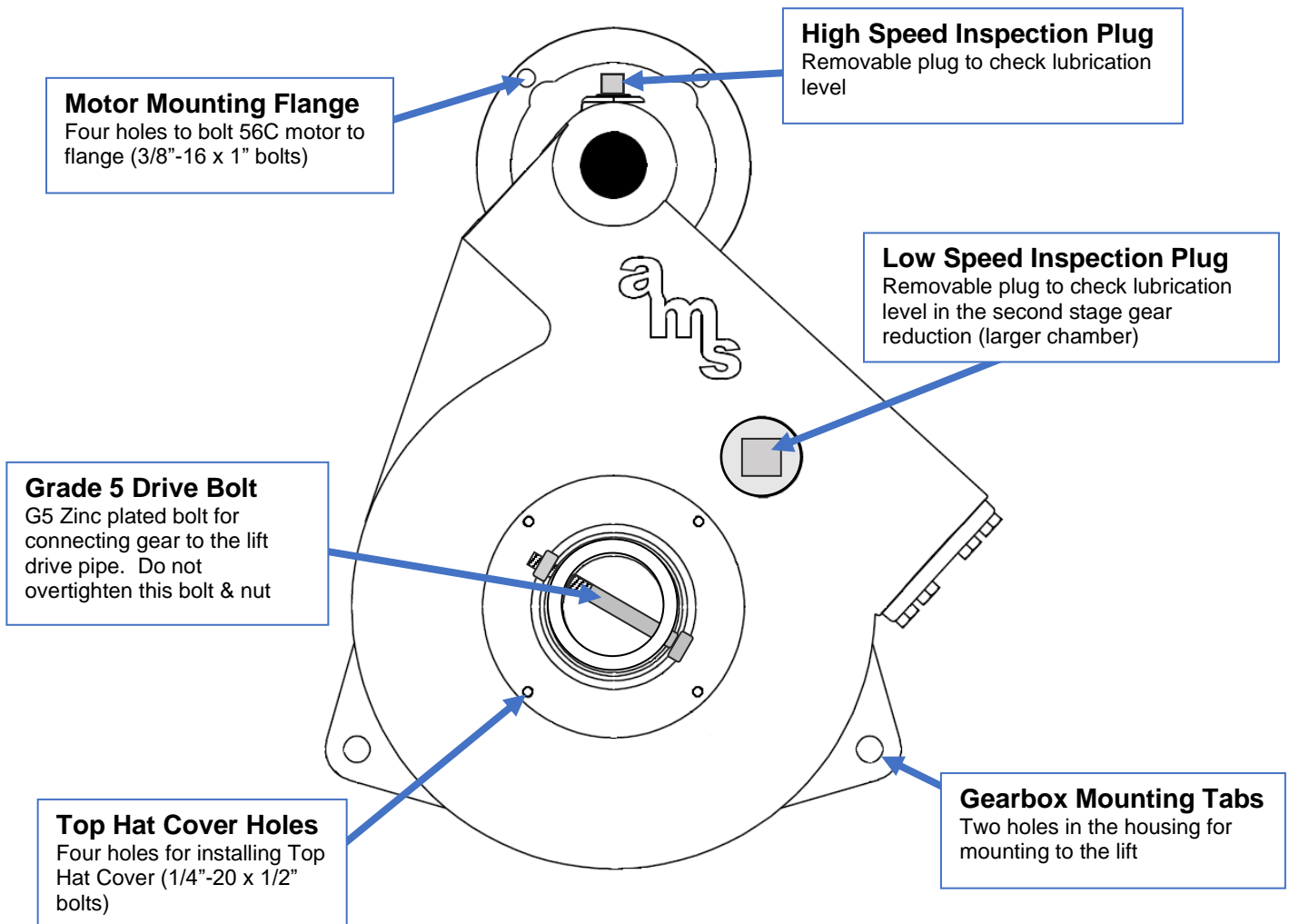

## Lubrication Information

### LEVELS

This drive has separate chambers for the high-speed and low-speed gearsets. The lubrication levels for both are shown to the right. Oil levels should be checked with the gearbox only in the position shown. Figure **A** represents the factory fill level. Figure **B** shows the maximum fill level. Overfilling the high-speed chamber can result in pressure buildup and seals blowing out. The drive is factory filled with roughly 12 oz in the high speed chamber and 64 oz in the low speed.

### LUBRICATION TYPE

The E-Gear uses a special lubricant designed for reducers known as **Mobilux EP023**. Only this lubricant should be used in the drive.

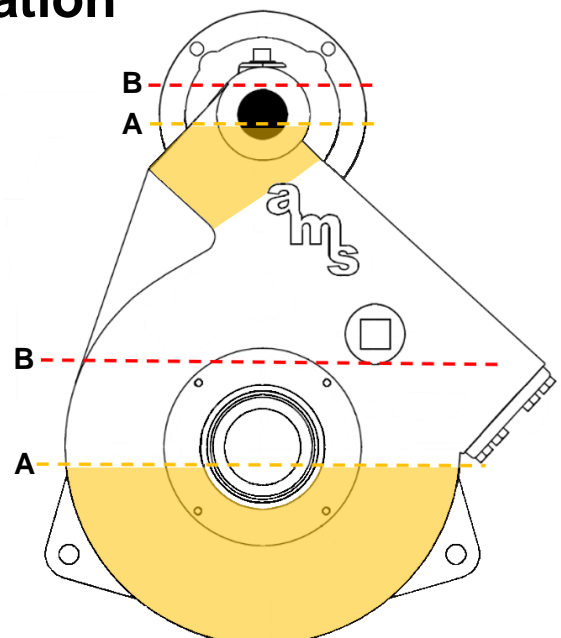

## GENERAL DESCRIPTION

The AMS E-Drive is a double reduction worm gear reducer contained in a single housing. It was designed specifically for a boatlift application. The input is a NEMA 56C to allow mounting of a standard electric motor directly onto the reducer. The output is a hollow shaft design that is sized to accommodate a standard 2" pipe (2.375" OD). The connection to the pipe utilizes the cross bolt identical to the current Flat Plate design. This design provides maintenance free service without grease lubrication intervals or belt drive adjustments.

## E-GEAR FEATURES

- **Housing** – The housing is made of lightweight cast aluminum for corrosion resistance in saltwater and humid environments. The housing has separate chambers for lubrication of the first and second stage gearsets individually. The housing is non-vented to prevent buildup of condensation.
- **Gearing** – The E-Gear is produced in multiple configurations of internal gearing. The gearing is utilizes very low helix angles to eliminate any potential for backdrifting. The large center distance of the low speed bull gearset results in lower tooth loads for a given output torque.
- **Bearings** – All shafts and gears are supported by deep groove ball bearings. The low speed wormshaft bearings are pre-lubricated and shielded to ensure proper lubrication and contain the lubrication in the high speed chamber.
- **Lubrication** – The E-Gear is factory filled by AMS with Mobilux EP023 gear lubricant. This semi-fluid grease has a high viscosity to withstand high shear stress and helps eliminate the potential for leaks.
- **Sealing** – The external seals of the E-Gear are spring-loaded triple lip seals to help protect the sealing lip from outside contaminants and shaft corrosion.
- **Mounting** – The E-Gear utilizes a through-shaft output style that allows the drive to be positioned at the end or even in the middle of the drive pipe.

## INSTALLATION

Suggested Mounting: The AMS E-Gear is designed to be shaft mounted. It is intended to have a *flexible mounting system* to allow the housing to move with the shaft slightly to prevent binding. This also eliminates the need for a precise machined mounting surface to secure the housing to the lift. It is important that the mounting tab on the housing not be put in a bind by rigidly attaching it to a mounting bracket. Rigid attachment will not allow the drive to flex with the lifting shaft and will eventually cause premature wear on seals, bearings and overstress gears, and potentially cause the housing to crack and/or leak. The drive should be mounted to the lift with a torque link as shown below:

### TORQUE LINK

It is very common for shaft-mounted gearboxes to incorporate some type of torque link to prevent the drive from rotating with the shaft. This torque link allows the gear to wobble or flex as the shaft rotates. The ideal position of this link is a 90 degree angle with a line drawn from the center of the shaft to the connecting point. See the figure right. As illustrated in the figure, it is acceptable for this angle to vary up to 30°. If the link angle varies more than that, the load in the link increases significantly.

### ORIENTATION

The E-Gear is designed to be mounted with the motor at the 12 o'clock position as demonstrated in the figure right. The gear may be rotated up to 30° in either direction if absolutely necessary for clearance. However, installing in a position over-rotated will cause internal components to lose lubrication and cause premature wear and possibly failure. The gear cannot be mounted upside down as well.

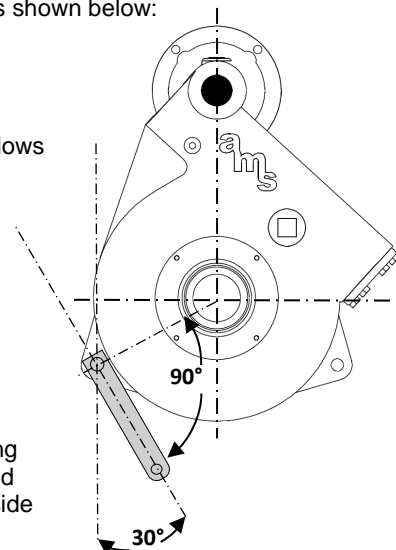

### SPECIAL NOTES

- **DRIVE BOLT** – The provided drive bolt is a grade 5, zinc plated, casehardened bolt that is used for specific reasons. Do not replace this bolt with a stainless-steel bolt as it will not withstand the shear force the bolt is subjected to. It is also extremely important that the bolt and nut **NOT** be tightened against the hub with any pressure. The provided nut is self-locking and can be tightened onto the bolt leaving a gap of 1/8 – 1/4" to the gear hub. If the bolt and nut is torqued down against the hub, the gear casting can be cracked. This error in installation will not be covered under warranty.
- **GEAR HUB** – The hub of the gear (output shaft) is bare, machined steel. The surface of this hub is coated in an anti-corrosive substance called Corrosion X heavy duty anti-rust lubrication. Do not wipe this lubrication off. If this surface is left clean, rust will build up and could tear the housing seals resulting in leaks. Periodically check this surface and reapply if necessary.
- **BEARING PLACEMENT** – Like all AMS products, it is important that the drive shaft or winding pipe being used on the lift be supported with bearings. AMS products are made to turn the pipe and are not to be load bearing. Therefore, it is important that the first bearing behind the E-Gear be as close as possible without being more than 10 inches away. If the bearing is too far away, the pipe/shaft can deflect which can bind the unit and put undue stress on the gears and cause multiple issues.
- **GEAR PERFORMANCE** - Unlike open gear systems like the AMS Flat Plate or PWC unit, enclosed gear systems such as the E-Gear conceal any signs of overload or installation misalignment. Open systems can make noise or smoke under extreme stress or binding. Since the E-Gear will conceal these issues, it is important that the motor amp draw be checked under load. If the voltage drops more than 4%, the concealed issue must be addressed before the job is completed.
- **MOTOR INSTALLATION** – The E-Gear is packaged with a small packet of anti-seize lubricant that is to be applied to the motor shaft before it is installed on the gear. Failure to apply this lubrication can result in the motor shaft seizing in the input shaft of the E-Gear. This can make it impossible to remove the motor if necessary. We have seen contractors break the housing or even pull the entire first stage gear set out with the motor when they try to separate the motor.
- **GEAR NOISE** – Due to the nature of the gear geometry, it is normal for the E-Gear to be slightly noisy in one direction. If the noise is abnormal or in both directions, it is quite possible that the unit has been either grossly overloaded or severely misaligned on the drive shaft. Another source of noise would be from low oil levels. Try to add lubricant to the high-speed chamber if low.
- **WARRANTY** – Check our website for warranty information on the E-Gear

**Specifications**

Output RPM	3.59 RPM (480:1) 2.87 RPM (600:1)	AMS Part Number (Gearbox only)	151100E480 (480:1) 151100E600 (600:1)
Output Torque	3,000-9,000 in lb	Item Weight	65 lb (without motor)
Input RPM	1725 RPM MOTORS ONLY	Package Weight	68 lb
Lubricant	Mobilux EP 023	Package Dimensions	22 x 20 x 9 in
Lubricant Capacity	Input Chamber: 12 oz Output Chamber: 64 oz		

